

A New Look at the Coding in Time-Modulated Arrays

Mehdi Gholami

School of Electrical and Computer
Engineering,
College of Engineering,
University of Tehran,
Tehran, Iran
gholami.mahdy@ut.ac.ir

Ehsan Sadeghi

School of Electrical and Computer
Engineering,
College of Engineering,
University of Tehran,
Tehran, Iran
sadeghi.ehsan@ut.ac.ir

Mohammad Neshat*

School of Electrical and Computer
Engineering,
College of Engineering,
University of Tehran,
Tehran, Iran
mneshat@ut.ac.ir

Received: 18 August 2021 - Accepted: 10 October 2021

Abstract—In this paper, we show that the digital code bits used in the coded time-modulated arrays (TMA) can be interpreted as vector elements, and with this new interpretation, a better understanding of the relationship between the codes and the amplitude/phase of the generated harmonic signals is obtained. Using such interpretation, we first select the proper codes for the maximum radiation in a coded TMA, and then we show that one can easily perform the beam steering in a TMA by electronically shifting the bits of the selected codes. Through full-wave simulations, we demonstrate the beam steering of a TMA without the use of any phase shifter, and only by shifting the digital code bits. The proposed interpretation can play an important role in reducing the complexity of the code selection in controlling of TMAs.

Keywords: Antenna array; Beam steering; Digital code; Metasurface; Time-coded modulation; Time modulated array

Article type: Research Article



© The Author(s).

Publisher: ICT Research Institute

I. INTRODUCTION

The need for extra control over antenna radiation led scientists to apply time modulation on one or more antenna parameters such as impedance, aperture size, aperture shape, frequency, phase, etc. Due to such modulation the characteristics of the radiation pattern changes as a function of time [1]. Moreover, because of harmonic generation, one can transmit information in several channels simultaneously by a single carrier frequency [2]. Time modulation of parameters can be applied to an array of emitters to create time-modulated array (TMA). TMAs provide innovative phased array

solutions for reaching better cost/performance tradeoffs [3].

TMA has been proposed as a viable solution for the next generation communication platforms. For example, time modulated multi-beam steered antenna array has been demonstrated in [4] that paves the way of using TMAs for 5G/6G technologies, or as an enabler for Internet of Things (IoT), a time-modulated antenna array for low-power wide-area network (LPWAN) receivers has been presented in [5]. A new architecture for wireless communications based on modulation of radiation patterns of a metasurface has

* Corresponding Author

been proposed in [6]. Through testing of a prototype, the authors of [6] have shown that such architecture has very high security and it is immune to blockage as the information is distributed through space and is recovered by several receivers. In [7], simultaneous multiuser communication service by TMAs has been demonstrated. The concept of TMA has been used to develop non-reciprocal elements such as circulators [8]. In [9], a technique has been introduced to estimate the direction of arrival of a target by applying TMA concept to antenna array. The first use of TMA concept was demonstrated in 1963 for side lobes reduction [10]. TMA consists of an array of radiating elements each fed by a time-modulated waveform. Time-modulation can be simply done by a switching sequence. The switching can be done in various ways, such as using a switch in the path of the carrier signal feeding the element or using reflective/transmissive elements that can be activated/deactivated. In either case, such switching operation results in the multiplication of the main signal by a switching pulse train in the time domain. The pulse train is obtained as a result of the on-off operation in the switch, and therefore, it can be referred as a digital switching. Such multiplication in the time domain becomes a convolution in the frequency domain, and can change the amplitude and phase of the generated harmonic frequencies in a desirable fashion by choosing proper pulse train sequences [11]. For this purpose, it is necessary to study the amplitude and phase properties of a pulse train that are the representative of the amplitude and phase of the time modulated waveforms.

The shape of the switching waveform affects the harmonic generation and subsequently their radiation pattern. Various shapes such as rectangular, trapezoidal, time-domain-raisedcosine (TDRC) [12] and sum-of-weighted-cosine (SWC) [13] waveforms have been introduced in the literature. For example, by using the switch-on instants of the time-modulated elements the array pattern has been optimized in [14]. In [15], [16] by dividing the rectangular waveform (pulse splitting) and optimizing their sequence, the unwanted harmonics could be suppressed. By pulse-shaping in [17], researchers could gain a better control over the harmonic patterns. Although these techniques gain many applications, shaping the switching wave is not practical when the number of elements of an array increases, e.g. reflect arrays based on Metasurface. In this regard, a new and breakthrough idea of using coding of switching pulses is introduced in [18] named coded time modulation. In coded time modulation the switching is done in a way that each switching sequence is a train of periodically repeating codes. Each code consists of a number of pulses applied to the switch control. Understanding the behavior and features of the codes used in time-coded modulation, helps to select the proper codes based on the applications and requirements of the system. This avoids going through complicated optimization process specially when there are a huge number of possible codes.

In this paper we introduce a new look at the coding in time modulation. We start with the properties of a pulse train from a harmonic perspective in a coded time-modulated array. We show that one can interpret the codes as vector elements, and with this new interpretation, a better understanding of the relationship between the codes and the amplitude/phase of the generated harmonic frequencies is obtained. Using such interpretation, we first predict the best codes for the maximum radiation in a coded TMA, and then we show that one can easily perform the beam steering only by electronically shifting the bits of the selected code. Finally, through fullwave simulations, we demonstrate the beam steering of a TMA without the use of any phase shifter, and only by shifted codes.

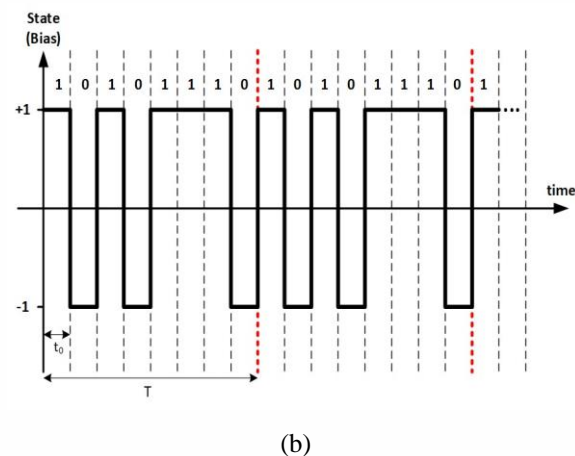
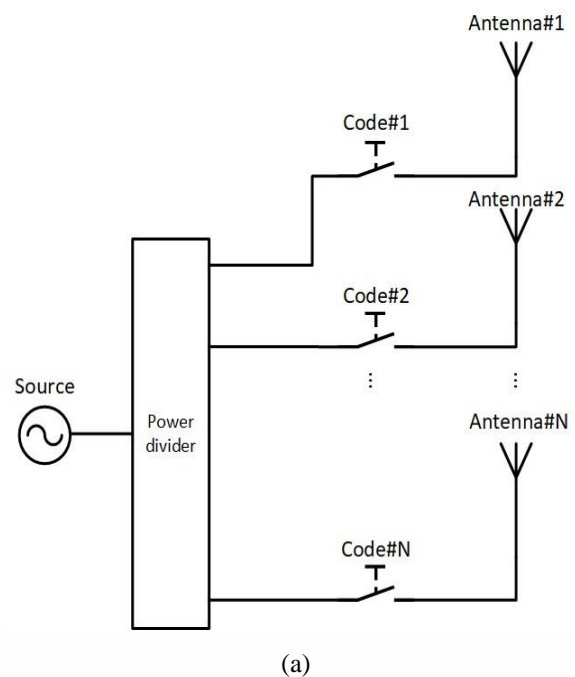

Fig 1. (a) Schematic of a coded TMA. The input signal to each antenna element is controlled by an RF switch. (b) An example code with the binary value of 10101110 applied to a switch. It is repeating by a period of T .

II. CODING IN TMA

Figure 1a illustrates a time-modulated array consisting of a linear array of N elements fed by a network of power divider and through RF switches. The input signal of each element can be switched according to a digital binary code as shown in Fig. 1b. It is assumed that the code modulation speed is much smaller than the RF source frequency. A code consists of a sequence of multiple bits that are periodically repeating. Accordingly, the time domain far-field pattern of such coded time-modulated linear array can be expressed as [18]

$$f(\theta, \phi, t) = e^{j2\pi f_c t} \sum_{p=1}^N E_p(\theta, \phi) S_p(t) \exp\left\{ \frac{j2\pi}{\lambda_c} (p-1) d \sin(\theta) \cos(\phi) \right\} \quad (1)$$

where $E_p(\theta, \phi)$ is the far-field pattern of p th element at the central frequency, f_c , of the RF source, θ and ϕ are the standard spherical coordinates, d is the distance between two adjacent elements, and λ_c is the central operational wavelength. According to the time switched array theory $S_p(t)$ is the time-modulated coefficient of the p th element [2], which is assumed as a coded pulse train. A coded pulse train is defined as

$$S(t) = \sum A_m U_m(t) \quad 0 < t < T \quad (2)$$

where L is the number of bits in each code, and $U_m(t)$ is a periodic pulse with periodicity of T as

$$U_m(t) = \begin{cases} 1, & (m-1)t_0 \leq t \leq mt_0 \\ 0, & \text{otherwise} \end{cases} \quad (3)$$

where $t_0 = T/L$ is the pulse width or duty cycle of $U_m(t)$, and A_m is the pulse amplitude in the time interval $(m-1)t_0 \leq t \leq mt_0$. Assuming the switch has two states, A_m can only take binary values. The Fourier series of $U_m(t)$ is obtained as

$$U_m(t) = \sum_{n=-\infty}^{\infty} c_{mn} \exp(j2\pi n f_0 t) \quad (4)$$

Where $f_0 = 1/T \ll f_c$, and the coefficients c_{mn} of the Fourier series are obtained from

$$c_{mn} = \frac{1}{T} \int_0^T U_m(t) \exp(-j2\pi n f_0 t) dt. \quad (5)$$

According to (5), the Fourier series complex coefficients of the coded pulse train $S(t)$ can be written as

$$\begin{aligned} \tilde{S}_n &= \sum_{m=1}^L A_m c_{mn} = \sum_{m=1}^L \frac{A_m}{T} \int_{(m-1)t_0}^{mt_0} e^{-j2\pi n f_0 t} dt \\ &= \sum_{m=1}^L \frac{A_m}{L} \text{sinc}\left(\frac{\pi n}{L}\right) \exp\left[-\frac{j\pi n(2m-1)}{L}\right]. \end{aligned} \quad (6)$$

The equivalent amplitude and phase of each harmonic order, n , produced by the code modulation can be calculated as

$$S_n = \left| \sum_{m=1}^L \frac{A_m}{L} \text{sinc}\left(\frac{\pi n}{L}\right) \exp\left[-\frac{j\pi n(2m-1)}{L}\right] \right| \quad (7)$$

$$\Psi_n = \arg \left\{ \sum_{m=1}^L \frac{A_m}{L} \text{sinc}\left(\frac{\pi n}{L}\right) \exp\left[-\frac{j\pi n(2m-1)}{L}\right] \right\} \quad (8)$$

where $\arg\{\cdot\}$ returns the phase value. As it will be shown in the next Section, using (7) and (8), any desired amplitude and phase for an arbitrary harmonic order, n , can be synthesized through selection of proper codes.

By taking Fourier transform of (1) and using (6), the farfield pattern for harmonic n is obtained as

$$F_n(\theta, \phi) = \sum_{p=1}^N E_p(\theta, \phi) \tilde{S}_n \exp\left\{ \frac{j2\pi}{\lambda_c} (p-1) d \sin(\theta) \cos(\phi) \right\} \quad (9)$$

It should be noted that S_{en} in (9) might be different for elements of the array designated by subscript p .

III. INTERPRETATION OF CODING

As previously mentioned, in a TMA, a repeating code consisting of L bits and periodicity of T , modulates the RF signal that is fed to each array element, and it produces harmonics whose amplitude and phase can be manipulated. The sequence and the length of bits, L , in a code are the degrees of freedom that enable one to control and manage the amplitude and phase of a particular harmonic order.

Representing a binary code as $A = A_1 A_2 A_3 \dots A_m \dots A_L$, and by careful inspection of (7) and (8), one can see that the amplitude and phase due to code A are basically the summation of L vectors that are assigned to each bit of A . The magnitude and phase of the corresponding vector to the m^{th} bit, A_m , of the harmonic order n in complex plane are obtained from

$$s_{nm} = \frac{A_m}{L} \text{sinc}\left(\frac{\pi n}{L}\right) \quad (10)$$

$$\psi_{nm} = -\frac{\pi n(2m-1)}{L} \quad (11)$$

Figure 2 shows the vector representation of bits in a 8-bit code for the first harmonic ($n = 1$). Considering an eight-bit code in the binary basis as 10001101, the amplitude and phase of the switching operation for the first harmonic is the vector summation of the individual bits as shown in Fig. 3.

It should be clear by now that the vector interpretation can help one to have a better view of the treatment of a code in switching operation. One interesting observation from this approach is that by shifting the bits of a code to the left or right, the resultant phase of the harmonic signal (vector) leads or lags as much as $\Delta\phi = 2\pi/L$ (for first harmonic) without changing the amplitude. This can be used to steer the beam in TMAs.

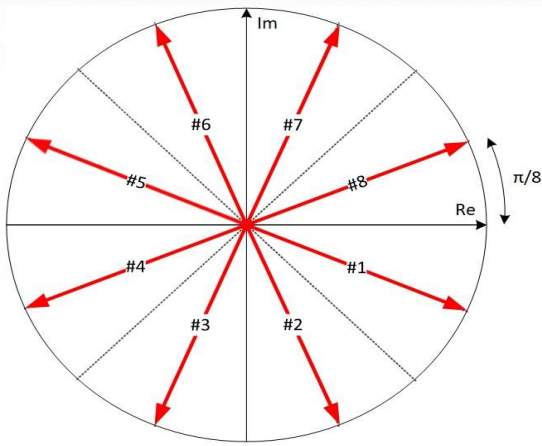

Fig 2. Vector representation of bits in a 8-bit code for the first harmonic ($n = 1$).

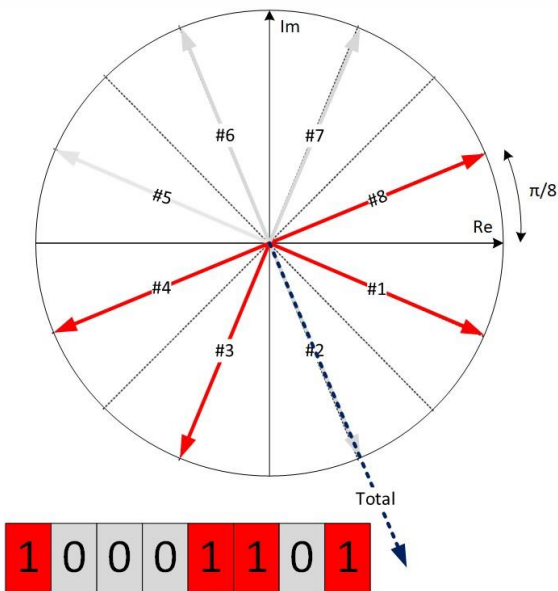

Fig 3. Illustration of the resultant amplitude and phase due to 10001101 code for the first harmonic ($n = 1$) based on vector interpretation of bits.

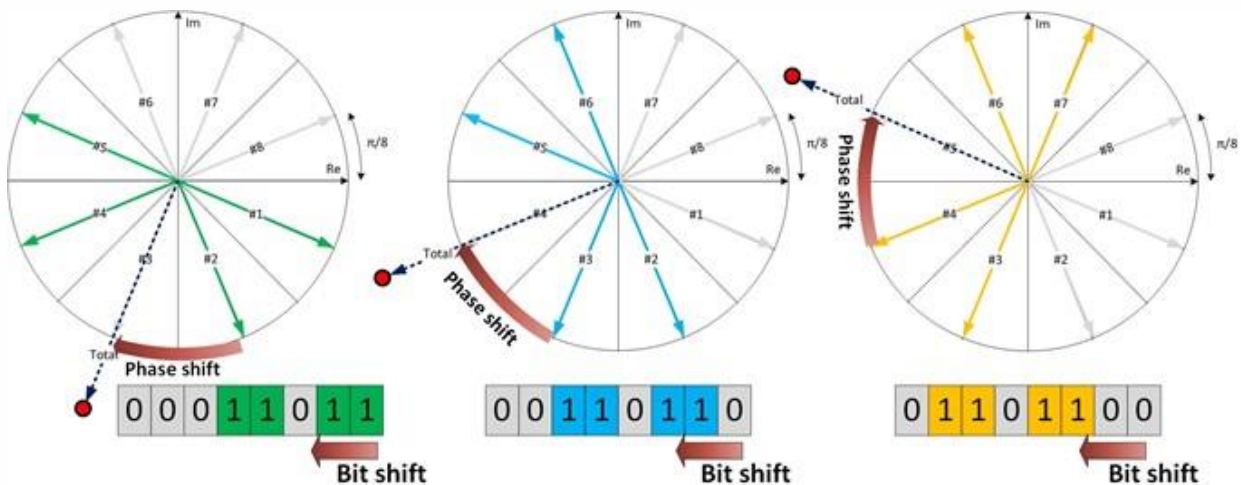

Fig 4. Illustration of phase change due to the shifting of the same code 10001101 as in Fig. 3 by one bit to the left for the first harmonic. It is clear that the amplitude remains constant.

In this way, a code is selected that provides all the features of the design criteria, then the same code is applied to each element of the array but with a certain number of bits shifted. Since the code is periodically applied to the switches, all switches see the same code but with some delay, which results in constant amplitude during beam steering.

Fig. 4 shows the amplitude and phase of the same code as in Fig. 3 for one-, two- and three-bit shifts. It is observed that 45, 90 and 135 degrees phase shifts are obtained for 1-, 2 and 3-bit shift, respectively. The proposed technique can be a good alternative for the phase shifters when they can not be an option of choice due to the high cost or technology limitations.

IV. SIMULATION RESULTS

In this section, we show that the proposed interpretation of bits as vector elements provides a powerful tool to predict the behavior of TMA in response to various codes.

Figure 5 shows a linear array consisting of ten halfwavelength electric dipoles spaced $\lambda/2$ apart. The central frequency of the antenna is $f_c = 3$ GHz. To feed the antenna elements, it is assumed that a power divider similar to Fig. 1a is used along with a switch before each antenna to disconnect and connect the excitation. For the sake of simplicity, it is assumed that the codes applied to the switches are similar with 4 bits. Choosing the repetition frequency of codes as 10 MHz, the first positive ($n = 1$) and negative ($n = -1$) harmonic frequency is 3.01 GHz and 2.99 GHz, respectively. Vector representation of bits in a 4-bit code for the first harmonic ($n = 1$) is shown in Fig. 6.

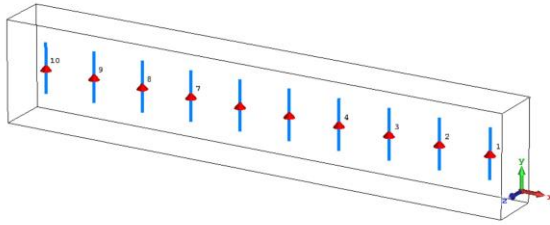

Fig 5. The geometry of a linear array consisting of ten half-wavelength dipoles with equal spacing.

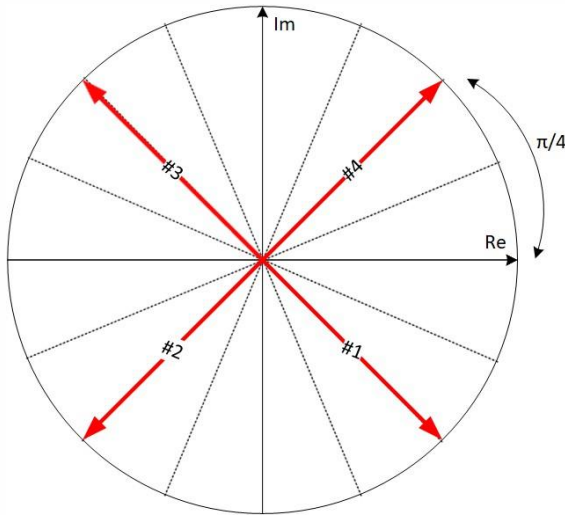

Fig 6. Vector representation of bits in a 4-bit code for the first harmonic ($n = 1$).

By inspecting Fig. 6, it becomes clear that in terms of the amplitude of the resultant vector of bits, the codes can be classified into three groups:

- Group1: 0011, 0110, 1001, 1100 (amplitude of resultant vector $\sqrt{2}$ times that of bit vector).
- Group2: 0001, 0010, 0100, 1000, 1110, 1101, 1011, 0111 (amplitude of resultant vector equal to that of bit vector).
- Group3: 0000, 1010, 0101, 1111 (amplitude of resultant vector zero).

It is worth noting that the resultant bit vector is equivalent to the phasor \vec{S}_n given in (6) in terms of the amplitude and phase. Moreover, according to (9) the amplitude of far-field pattern is proportional to the amplitude of the resultant bit vector when all elements are switched with the same code. Therefore, one would expect that the amplitude of the radiation pattern of the aforementioned linear array is higher by 3 dB for the codes in Group1 as compared to that for the codes in Group2.

Figure 7 shows the radiation pattern of all codes in Group1 and Group2 calculated from (9) for the first harmonic ($n = 1$) of the linear array. It is evident that the codes relevant to maximum amplitude of the radiation pattern was easily predicted above through the proposed bit vector representation.

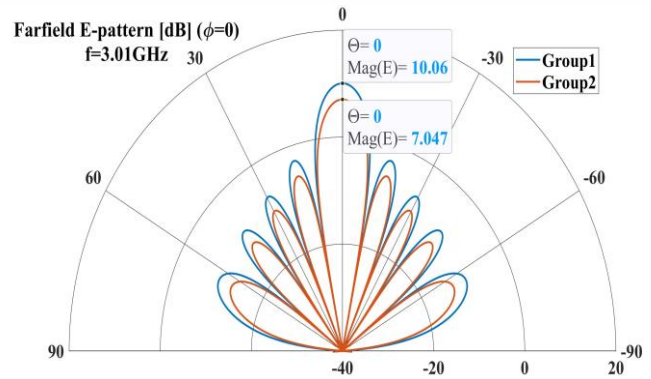

Fig 7. Simulated pattern for the linear TMA coded by 4 bits for two groups of codes as explained in the text.

In another attempt, full-wave simulations for the same linear array have been performed to demonstrate the phase change capability of the coded time-modulated arrays based on the bit shift technique proposed in the previous Section. The code applied to the switches has twelve bits and the repetition frequency of each code is 10 MHz. The full-wave simulation of this structure was conducted by CST, a commercial EM simulator, using time-domain solver.

By choosing a 12-bit code, a phase difference of $\Delta\phi = 2\pi/L = 360^\circ/12 = 30^\circ$ is achieved for each bit shifting in the code for the first harmonic. On the other hand, the relationship between the beam steering angle (θ_0) and the phase difference between adjacent elements are given as

$$\Delta\phi = \frac{2\pi d}{\lambda} \sin(\theta_0) \tag{12}$$

By substituting $\Delta\phi = \frac{2\pi}{L}$ and $d = \frac{\lambda}{2}$ in (12) one can calculate the beam steering angle as

$$\theta_0 = \text{asin}\left(\frac{2}{L}\right) \xrightarrow{L=12} \theta_0 = 9.59^\circ$$

If a larger steering angle is desired, one has to increase the phase difference between the adjacent elements. This can be easily achieved by shifting more bits. Table I shows the amount of steering angle per number of shifted bits in the adjacent switches.

Figure 8 shows full-wave simulated pattern of the TMA illustrating the beam steering due to consecutive bit shifting between adjacent switches of the array elements. As can be seen, using this technique, the pattern can be steered at different angles with a slight change in the pattern for large angles. One advantage of this technique is that the operation of bit shifting can be programmed in software level without any additional phase tuning hardware.

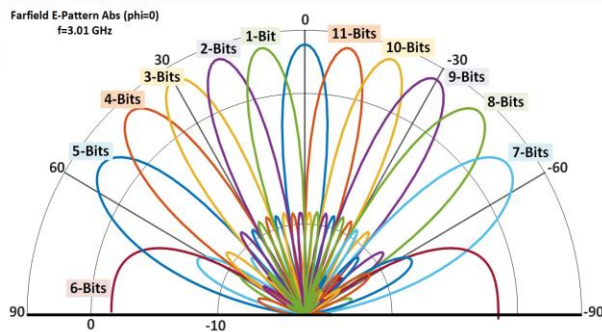

Fig 8. Full-wave simulated pattern of the TMA illustrating the beam steering due to consecutive bit shifting between adjacent switches of the array elements. The corresponding number of shifted bits are shown for each pattern.

V. CONCLUSION

The proposed interpretation of bits as vector elements provides an excellent insight into the operation of coded TMAs, and it gives a powerful tool to synthesize any desired phase/amplitude for different harmonics. Through this method, we showed that the shifting of bits leads to the phase change of the harmonics without changing their amplitude. Using this method and with the help of full-wave simulation, we demonstrated beam steering in a linear array that is excited by the coded time modulation. With the help of this method more interesting applications of coded TMAs can be expected in future wireless communication platforms. Providing the high degrees of freedom in the codes and the harmonics, TMAs can be used for multi-user service, and beam scanning. Moreover, well designed coded TMAs can be used to develop extremely low power transmitter sensors by proper re-modulating the already available WiFi and other wireless waves in the environment as the carrier.

REFERENCES

- [1] R. W. Bickmore and R. Hansen, "Time versus space in antenna theory," *Microwave scanning antennas*, vol. 3, p. 15, 1966.
- [2] H. E. Shanks and R. W. Bickmore, "Four-dimensional electromagnetic radiators," *Canadian Journal of Physics*, vol. 37, no. 3, pp. 263–275, 1959.
- [3] G. Franceschetti, J. Tatoi, and G. Gibbs, "Timed arrays in a nutshell," *IEEE transactions on antennas and propagation*, vol. 53, no. 12, pp. 4073–4082, 2005.
- [4] A. Chakraborty, G. Ram, and D. Mandal, "Time-modulated multibeam steered antenna array synthesis with optimally designed switching sequence," *International Journal of Communication Systems*, vol. 34, no. 9, p. e4828, 2021.
- [5] G. Bogdan, K. Godziszewski, and Y. Yashchishyn, "Time-modulated antenna array with beam-steering for low-power wide-area network receivers," *IEEE Antennas and Wireless Propagation Letters*, vol. 19, no. 11, pp. 1876–1880, 2020.
- [6] T. J. Cui, S. Liu, G. D. Bai, and Q. Ma, "Direct transmission of digital message via programmable coding metasurface," *Research*, vol. 2019, 2019.
- [7] W. Tang, M. Z. Chen, J. Y. Dai, Y. Zeng, X. Zhao, S. Jin, Q. Cheng, and T. J. Cui, "Wireless communications with programmable metasurface: New paradigms, opportunities, and challenges on transceiver design," *IEEE Wireless Communications*, vol. 27, no. 2, pp. 180–187, 2020.

- [8] S. Taravati and A. A. Kishk, "Space-time modulation: Principles and applications," *IEEE Microwave Magazine*, vol. 21, no. 4, pp. 30–56, 2020.
- [9] S. Vakalis and J. A. Nanzer, "Millimeter-wave angle estimation of multiple targets using space-time modulation and interferometric antenna arrays," *IEEE Transactions on Microwave Theory and Techniques*, pp. 1–1, 2021.
- [10] W. Kummer, A. Villeneuve, T. Fong, and F. Terrio, "Ultra-low sidelobes from time-modulated arrays," *IEEE Transactions on Antennas and Propagation*, vol. 11, no. 6, pp. 633–639, 1963.
- [11] J. Y. Dai, J. Zhao, Q. Cheng, and T. J. Cui, "Independent control of harmonic amplitudes and phases via a time-domain digital coding metasurface," *Light: Science & Applications*, vol. 7, no. 1, p. 90, 2018.
- [12] E. T. Bekele, L. Poli, P. Rocca, M. d'Urso, and A. Massa, "Pulseshaping strategy for time modulated arrays—analysis and design," *IEEE Transactions on Antennas and Propagation*, vol. 61, no. 7, pp. 3525–3537, 2013.
- [13] R. Maneiro-Catoira, J. C. Bregains, J. A. Garcia-Naya, and L. Castedo, "Enhanced time-modulated arrays for harmonic beamforming," *IEEE Journal of Selected Topics in Signal Processing*, vol. 11, no. 2, pp. 259–270, 2016.
- [14] L. Poli, P. Rocca, L. Manica, and A. Massa, "Pattern synthesis in time-modulated linear arrays through pulse shifting," *IET Microwaves, Antennas & Propagation*, vol. 4, no. 9, pp. 1157–1164, 2010.
- [15] S. Yang, Y. B. Gan, A. Qing, and P. K. Tan, "Design of a uniform amplitude time modulated linear array with optimized time sequences," *IEEE Transactions on Antennas and Propagation*, vol. 53, no. 7, pp. 2337–2339, 2005.
- [16] Q. Zhu, S. Yang, L. Zheng, and Z. Nie, "Design of a low sidelobe time modulated linear array with uniform amplitude and sub-sectional optimized time steps," *IEEE Transactions on Antennas and Propagation*, vol. 60, no. 9, pp. 4436–4439, 2012.
- [17] L. Poli, T. Moriyama, and P. Rocca, "Pulse splitting for harmonic beamforming in time-modulated linear arrays," *International Journal of Antennas and Propagation*, vol. 2014, 2014.
- [18] L. Zhang, X. Q. Chen, S. Liu, Q. Zhang, J. Zhao, J. Y. Dai, G. D. Bai, X. Wan, Q. Cheng, G. Castaldi, V. Galdi, and T. J. Cui, "Spacetime-coding digital metasurfaces," *Nature Communications*, vol. 9, no. 1, p. 4334, 2018.



Mehdi Gholami received his M.Sc. degree in Electrical Engineering (Fields and Waves) from Amirkabir University of Technology (Tehran Polytechnic) in 2008. He joined Photoelectronics Research Group in the School of Electrical and Computer Engineering of the University of Tehran as a Ph.D. student in 2017. Now he is working on Space-time-code modulated arrays for THz communication in his Ph.D. thesis. His research interests include Time-Modulated Arrays, THz and mm-Wave Applications, Reconfigurable Intelligent Surfaces and Communication System Design.



Ehsan Sadeghi received his B.Sc. degree in Electrical Engineering from University of Tabriz. He joined Photoelectronics group in the School of Electrical and Computer Engineering of the University of Tehran as a M.Sc. Student in 2020. Now he is working on Metasurface Antennas as his M.Sc. thesis. He is an elected B.Sc. student of University of Tabriz in 2018. His research interests are Metasurface Antennas, Reconfigurable Antennas and Time-Modulated Array.



Mohammad Neshat is an Assistant Professor at the School of ECE, University of Tehran, Iran. He is the founder of THz Photoelectronics Research Group, and co-founder of THz Devices & Systems Lab at the University of Tehran. He received his B.Sc. degree from the Isfahan University of Technology, Iran, in 1998, and his M.Sc. degree from the Sharif University of Technology, Iran, in 2000, both in Electrical Engineering. From 2000 to 2005, he was R&D Engineer involved in the design, fabrication and test of various microwave components and systems for telecommunication industry. He received his Ph.D. degree from the University of Waterloo, Canada in 2009 in the field of THz photonics. In 2010, he was Postdoctoral Fellow with the Centre for Intelligent Antenna and Radio Systems (CIARS), University of Waterloo. During 2011-2012, he was Postdoctoral Fellow with the Physics & Astronomy Department at the Johns Hopkins University, USA, where he successfully developed the instrumentation for THz time-domain spectroscopic ellipsometry. Dr Neshat is the recipient of various awards for his academic/research achievements including Ontario Graduate Scholarship (2008-2009), University of Waterloo President Graduate Scholarship (2008-2009), Postdoctoral Fellowship Award from Johns Hopkins University (2011-2012), TWAS-COMSTech Joint Research Grants (2015), and ICSN6 Best Poster Award (2016). His current research interests are on development of novel THz/mmWave devices and systems for emerging applications.